

CE  
 RoHS  
 11K21-25.4  
 DINGS' MOTION  
 Work order  
 DATE REV00

REVISION			
REV.	DATE	DESCRIPTION	DRAWN BY

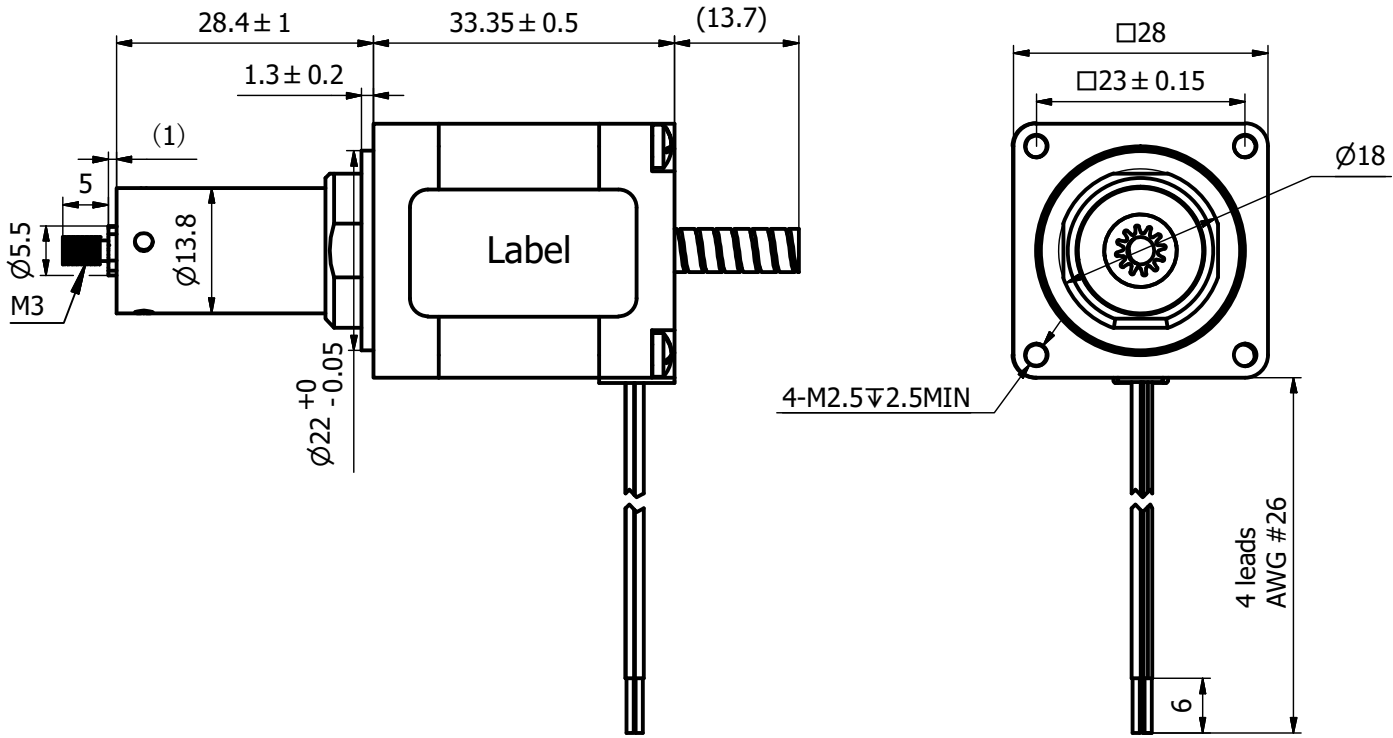

**Notes,**  
 1.To maximize output force and life of linear actuators,  
 radial load on lead screws should be avoided or be kept at a minimum.

CUSTOMER		NOTICE TO PERSONS RECEIVING THIS DRAWING													
WIRING CHART		EXCITATION SEQUENCE				UNLESS OTHERWISE SPECIFIED ALL DIMENSIONS ARE IN MILLIMETERS AND TOLERANCES ARE AS BELOW PER ISO2768-ck.				DRAWN		DATE			
		CW $\longrightarrow$ Red A+ +    - Red/wht A- -    + Green B+    +    - Grn/wht B-    -    + CCW $\longleftarrow$				LINEAR		ANGULAR		APPRVD		DATE			
						0~3		±0.2		0~10		±1.5°		MODEL 11K21-25.4 SIZE A3 SHEET 1 OF 1 SCALE 1: 1 REV 00	
						3~6		±0.5		10~50		±1°			
						6~30		±0.8		50~120		±30'			
						30~120		±1.5		120~400		±15'			