

6.2.2 Recommended CANopen dongle

In order to use the CANopen Tester tool and upgrade utility for the MDrive you must purchase the MD-CC500-000 communication cable. When purchased from us, the user interface software for upgrading and prototyping is included. This is required to upgrade the firmware in the MDrive updates become available.

This device is also available from phytec at: <http://www.phytec.com/can/hardware/pccaninterface/peakusb.htm>, but does not include the CANopen Tester and upgrader software.

Interface cable construction

To connect the MD-CC500-000 dongle to the MDrive product an interface cable will need to be constructed. The figure below shows the parts required.

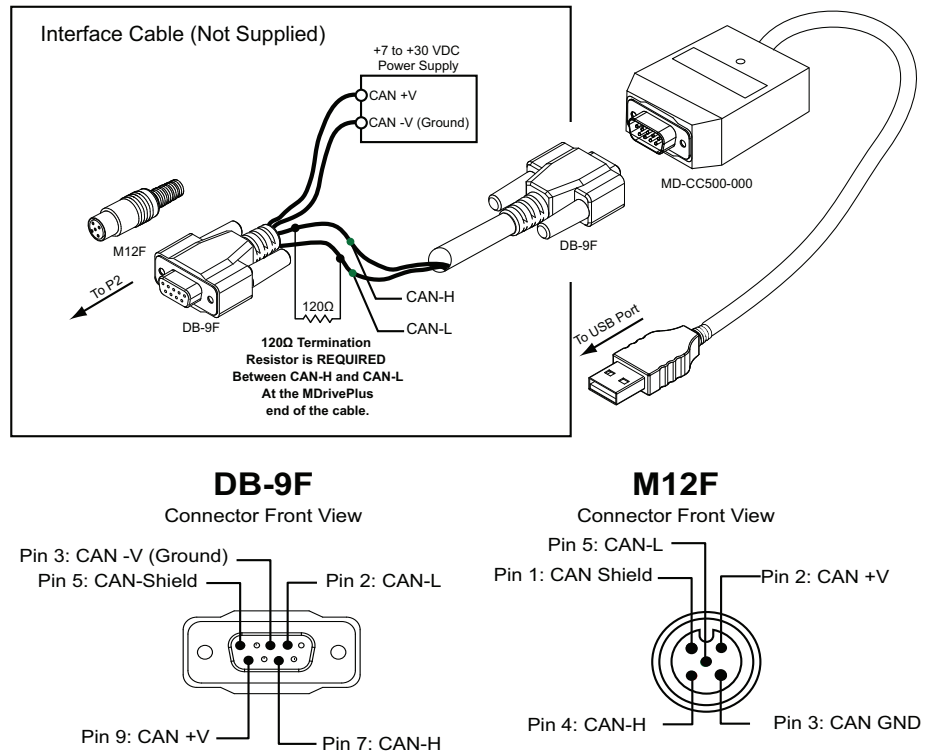

Figure 6.2 MD-CC500-000 USB to CANopen commissioning cable

Installation Instructions

- 1) Install the MD-CC500-000 adapter per the Phytec PCAN-USB Operating Instructions included on the PEAK CD included with the product.
- 2) Install the CANopen Tester software available online at <http://www.imshome.com/>
- 3) Using the interface cable (not supplied), connect the MDrive product to the MD-CC500-000.
- 4) Apply power to the MDrive product.