

4 Connection and interface

⚠ DANGER
<p>EXPOSED SIGNALS</p> <p>Hazardous voltage levels may be present if using an open frame power supply to power the product.</p> <p>Failure to follow these instructions will result in death or serious injury.</p>

⚠ CAUTION
<p>SWITCHING DC POWER/HOT PLUGGING</p> <p>Do not connect or disconnect power, logic, or communications while the device is in a powered state.</p> <p>Remove DC power by powering down at the AC side of the DC power supply.</p> <p>Failure to follow these instructions can result in equipment damage.</p>

4.1 Interfacing communications

Communications interface, connector pin configuration and specifications are common to all NEMA sizes of the MDrive Hybrid. Connectivity information is located in Part 1 of this document, Section 1.4

4.2 Interfacing DC power

See part 1 of this document, section 3, for recommended power cable configurations.

⚠ CAUTION
<p>OVER VOLTAGE</p> <p>The DC voltage range for the MDrive 23 Hybrid is +12 to +60 VDC. Ensure that motor back EMF is factored into your power supply size calculations.</p> <p>Allow 3.0 A maximum power supply output current per MDrive in the system. Actual power supply current will depend on voltage and load.</p> <p>Failure to follow these instructions can result in equipment damage.</p>

4.2.1 Recommended power supply characteristics

	+12 to +60 VDC
Type	Unregulated linear
Ripple	± 5%
	3.0 A (per MDrive 23)

Table 4.1 Recommended power supply characteristics

4.2.2 Recommended wire gauge

Cable Length: Feet (meters)	10 (3.0)	25 (7.6)	50 (15.2)	75 (22.9)	100 (30.5)
Amps Peak	Minimum AWG				
1 Amp Peak	20	20	18	18	18
2 Amps Peak	20	18	16	14	14
3 Amps Peak	18	16	14	12	12

Table 4.2 Recommended power supply wire gauge

4.2.3 P2 — 2-pin locking wire crimp interface

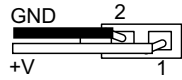

Pin Numbers	Signal	Prototype development cable wire colors
1	+12 to + 60 VDC	Red
2	Power supply return (ground)	Black

Table 4.3 Power and ground connections, 2-pin locking wire crimp

Connectivity accessories

- Mating connector kit CK-04 (contains 5 connector shells and the appropriate quantity of pins to make 5 cables)
- Prototype development cable (10’/3.0 m)..... PD02-2300-FL3

Manufacturer (Tyco) part numbers

- Connector shell.....794617-2
- Pins.....794610-1

4.2.4 Power Interface using Drive Protection Module DPM75

The DPM75 Drive Protection Module will limit surge currents for one (1) MDrive 23 Hybrid at up to 60 VDC to allow switching DC Power.

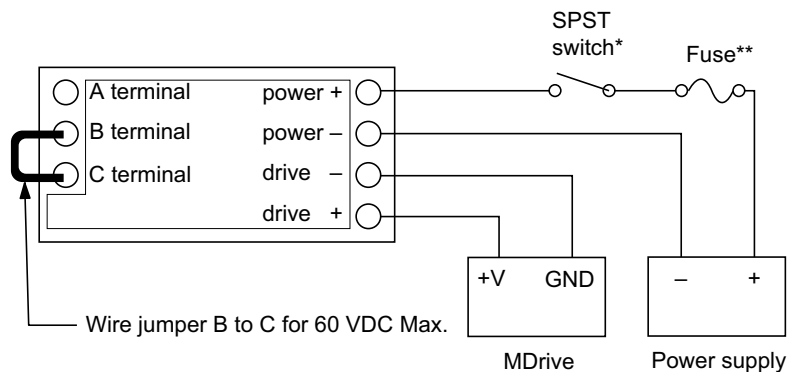

* Do not switch negative side of supply
 **Fuse = 6.3 Amp slow blow (recommended: Bussman S505-6.3A or Littelfuse 215006.3). The fuse is optional.

Figure 4.1 DPM75 Drive Protection Module

4.3 Interfacing I/O

See part 1 of this document, section 4, for I/O interface configurations and methods.

CAUTION
<p>ELECTRICAL OVERSTRESS</p> <p>The general purpose I/O is tolerant to +24 VDC. The following listed I/O point is TTL level and only tolerant to +5 VDC:</p> <p style="text-align: center;">1) Capture/Trip</p> <p>Do not exceed +5 VDC on these points.</p> <p>Failure to follow these instructions can result in equipment damage.</p>

4.3.1 P1 — 14-pin locking wire crimp interface (expanded I/O)

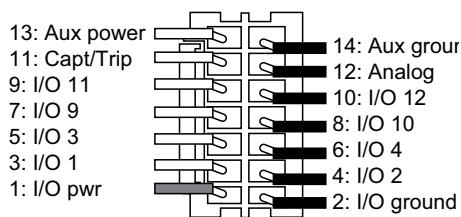

Pin Numbers	Signal	Prototype development cable wire colors (twisted pairs)
1	I/O power	Red
2	I/O ground	Black
3	General purpose I/O 1	Orange
4	General purpose I/O 2	Black
5	General purpose I/O 3	Brown
6	General purpose I/O 4	Black
7	General purpose I/O 9	Yellow
8	General purpose I/O 10	Black
9	General purpose I/O 11	Blue
10	General purpose I/O 12	Black
11	Capture output/trip input	Green
12	Analog input	Black
13	Aux power	White
14	Aux ground	Black

Table 4.4 I/O connections, 14-pin locking wire crimp

Connectivity accessories

Mating connector kit CK-09
(contains 5 connector shells and the appropriate quantity of pins to make 5 cables)

Prototype development cable (10'/3.0 m)..... PD14-2334-FL3

Manufacturer (JST) part numbers

Connector shell.....PADP-14V-1-S

Pins..... SPH-001T0.5L

Revision R100110

4.3.2 P1 — 14-pin locking wire crimp interface (ethernet version)

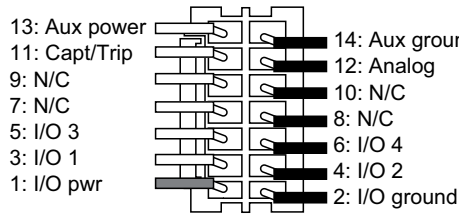

Pin Numbers	Signal	Prototype development cable wire colors (twisted pairs)
1	I/O power	Red
2	I/O ground	Black
3	General purpose I/O 1	Orange
4	General purpose I/O 2	Black
5	General purpose I/O 3	Brown
6	General purpose I/O 4	Black
7	Not connected	Yellow
8	Not connected	Black
9	Not connected	Blue
10	Not connected	Black
11	Capture output/trip input	Green
12	Analog input	Black
13	Aux power	White
14	Aux ground	Black

Table 4.5 I/O connections, ethernet version, 14-pin locking wire crimp

Connectivity accessories

Mating connector kit CK-09
(contains 5 connector shells and the appropriate quantity of pins to make 5 cables)

Prototype development cable (10'/3.0 m)..... PD14-2334-FL3

Manufacturer (JST) part numbers

Connector shell..... PADP-14V-1-S

Pins..... SPH-001T0.5L

4.4 Connectivity accessory details

4.4.1 RS-422/485 communications converter cables

USB to 10-pin wire crimp connector P2
P/N: MD-CC402-001

Electrically isolated in-line USB to RS-422/485 converter pre-wired with mating connector to conveniently program and set configuration parameters

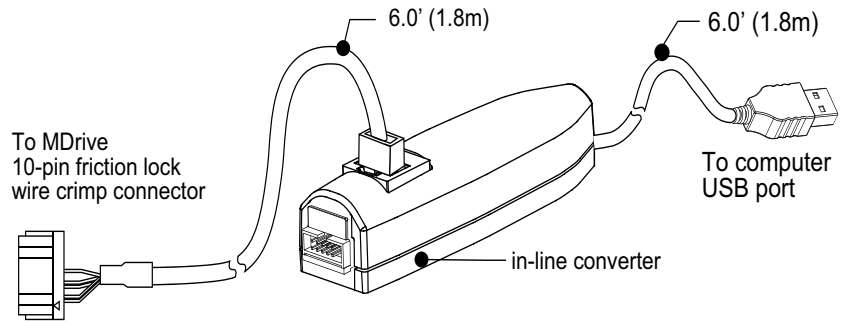
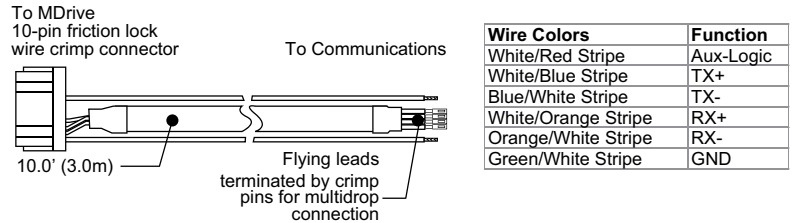

Figure 4.1 MD-CC402-001 communications converter cable

4.4.2 Prototype development cables

Flying leads to 10-pin wire crimp connector
 P2 -P/N: PD10-1434-FL3

Used in conjunction with the MD-CC402-001 communications converter cable to facilitate multi-drop RS-422/485 communications.



Note: If not using Aux-Logic
 Remove Wire (White/Red Stripe)

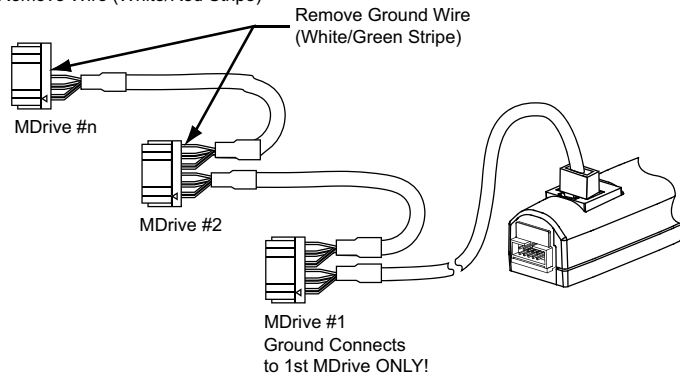

Figure 4.3 Multi-drop communications using the PD10-1434-FL3

Procedure

- 1) Remove ground wire (unless this is the first system MDrive, green/white stripe)
- 2) Remove aux-logic (if not used, red/white stripe)
- 3) Connect pre-crimped flying leads as shown in Figure 5.7 below

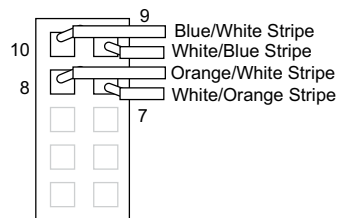

Figure 4.4 Wiring a second PD10-1434-FL3 into the 10-pin wire crimp connector.

Flying leads to 14-pin locking wire crimp connector P2 -P/N: PD14-2334-FL3

The PD14-2334-FL3 prototype development cable is used to rapidly interface the MDrive 23 Hybrid to the users controller. This 10' (3.0 m) cable consists of a 14-pin locking wire crimp connector to plug directly into the MDrive P1 connector with flying leads on the opposite end to interface to I/O devices.

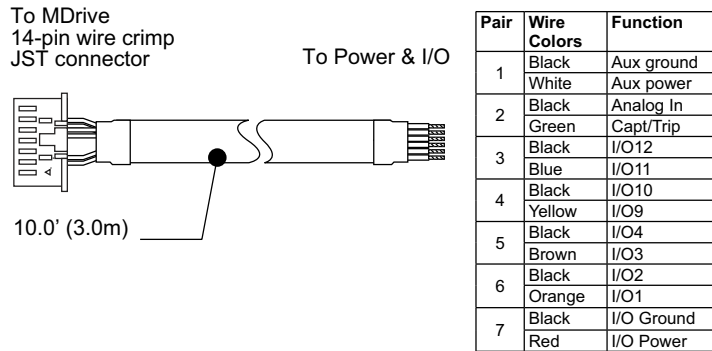

Figure 4.5 Prototype development cable PD14-2334-FL3

Flying leads to 2-pin locking wire crimp connector P2 -P/N: PD02-2300-FL3

The PD02-2300-FL3 prototype development cable is used to rapidly interface the MDrive 23 Hybrid to the users DC power supply. This 10' (3.0 m) cable consists of a 2-pin locking wire crimp connector to plug directly into the MDrive P3 connector with flying leads on the opposite end to interface to DC power.

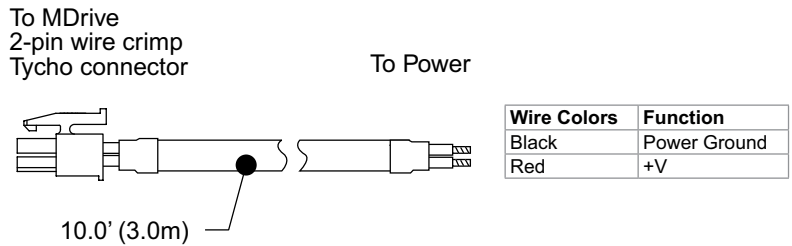

Figure 4.6 Prototype development cable PD02-2300-FL3

4.4.3 Mating connector kits

Use to build your own cables. Kit contains 5 mating shells with pins. Cable not supplied. Manufacturer's crimp tool recommended.

Mates to connector:

- P2 10-pin wire crimp.....CK-02
- P1 14-pin wire crimp.....CK-09
- P3 2-pin wire crimp.....CK-04

Revision R100110