



intelligent motion systems, inc.
Excellence in Motion™

OSC-805H

**ANALOG SPEED CONTROL BOARD
FOR IM805H DRIVER**

QUICK REFERENCE



370 N. MAIN ST., PO BOX 457, MARLBOROUGH, CT 06447
PH: (860) 295-6102, FAX: (860) 295-6107
Internet: www.imshome.com, E-Mail: info@imshome.com

OSC-805H Quick Reference/ Installation Guide

The primary function of this guide is to acquaint the user with the specifications, basic wiring and configuration of the OSC-805H Analog Speed Control Board. The full product manual is available in Acrobat PDF format on the IMS Product CD. It also may be downloaded from the IMS web site at www.imshome.com.

Notes And Warnings

Please observe the following when handling, connecting and using your IM805H Driver and OSC-805H Analog Speed Control Board. Failure to observe these points may result in damage to the drive. All warranty and disclaimer information is located in the full product manual and should be referenced for more information.

- The OSC-805H and IM805H components are sensitive to Electrostatic Discharge (ESD). All handling should be done at an ESD protected workstation.
- Hazardous Voltage Levels may be present if using an open frame power supply to power the OSC-805H and IM805H.
- The Power Supply output voltage must not exceed the maximum input voltage of the OSC-805H and IM805H.
- Do not apply power to the OSC-805H or IM805H without proper heatsinking or cooling. The maximum rear plate temperature of the IM805H is 70°C!
- The rear mounting surface of the IM805H driver contains various voltages and must be kept isolated when attached to a conductive surface!

OSC-805H Thermal Specifications

	Range
Ambient Temperature	0 to +50°C
Storage Temperature	-40 to +125°C
Maximum Temperature	+70°C

OSC-805H Mechanical Specifications

Dimensions in Inches (mm)

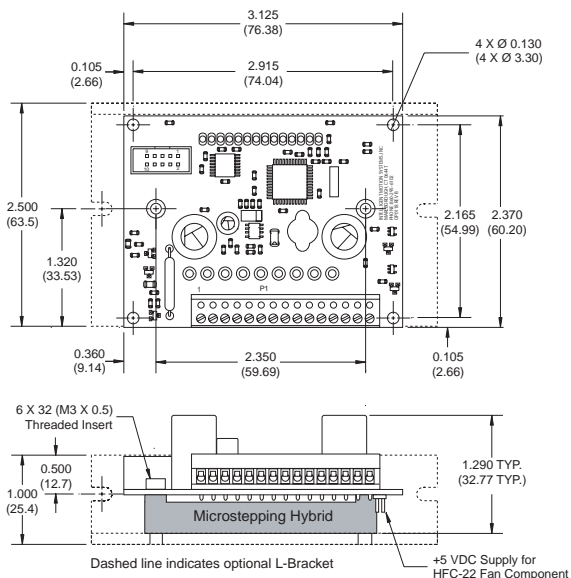

OSC-805H Electrical Characteristics

Specification	Test Condition	Min	Typ	Max	Unit
Input Voltage (+V) Range		24		75	V
A/D Resolution			10		Bit
Speed Control Potentiometer Resistance			10		kΩ
Speed Control Input Voltage		0		5	V
Phase Output Current	Peak			7	A
Low Level Input Voltage	Stop/Start, Direction and Step Clock	0		1.5	V
High Level Input Voltage	Stop/Start, Direction and Step Clock	3.0		5.0	V
Low Level Input Voltage	Enable	0		1.65	V
High Level Input Voltage	Enable	3.85		5.0	V
Input Pull-up Resistance (to +5 VDC)	Stop/Start, Direction, Step Clock, Enable		4.99		kΩ
Output Drain-Source Voltage	Direction and Step Clock Outputs			80	V
Output Drain Current	Direction and Step Clock Outputs			120	mA
Drain-Source On-Resistance	Direction and Step Clock Outputs			6	Ω

Connectors

P1 Connector and Pin Assignments

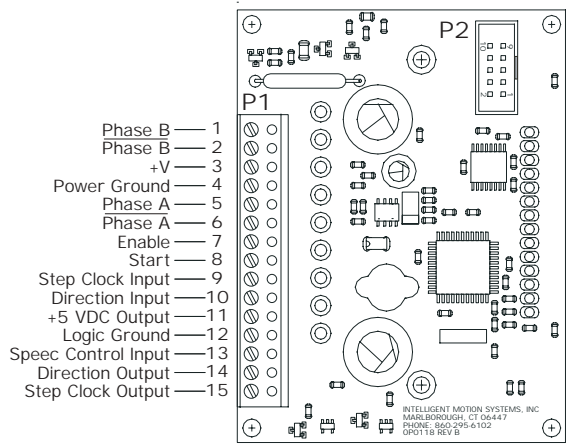

Pin #	Pin Name	Description
1	Phase B	Phase B of the stepping motor.
2	Phase B̄	Phase B̄ of the stepping motor.
3	+V	+24 to +75 VDC unregulated power supply input.
4	Power Ground	Power supply ground (return).
5	Phase Ā	Phase Ā of the stepping motor.
6	Phase A	Phase A of the stepping motor.
7	Enable	Active HIGH driver enable input. Internally pulled-up to +5 VDC.
8	Start	Active LOW start input enables the internal step clock generator. Internally pulled-up to +5 VDC.
9	Step Clock Input	Step clock input. Internally pulled-up to +5 VDC.
10	Direction Input	CW/CW direction input. Internally pulled-up to +5 VDC.
11	+5 VDC Output	+5 VDC Output (10kΩ Potentiometer/Joystick signal end).
12	Logic Ground	Logic Ground (10kΩ Potentiometer/Joystick ground).
13	Speed Control Input	0 to +5 VDC Speed Control Input (10kΩ Potentiometer/Joystick wiper).
14	Direction Output	Buffered direction output.
15	Step Clock Output	Buffered step clock output.

P2 Connector and Pin Assignment

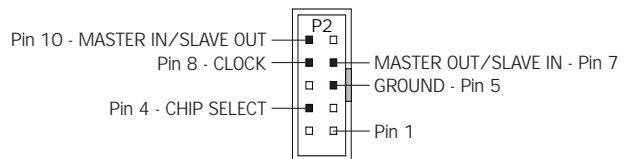

Pin # *	Pin Name	Description
4	CS	Chip Select
5	GND	Communications ground.
7	MOSI	Master Out/Slave In
8	CLK	Step Clock
10	MISO	Master In/Slave Out

* Numbers not shown are no connect.

Connecting the SPI* Interface

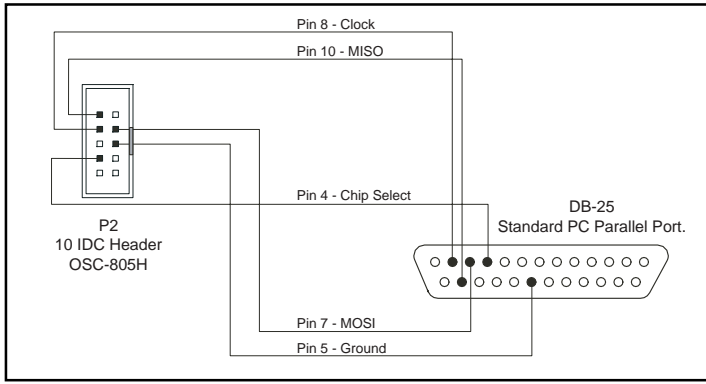

* SPI is the acronym for Serial Peripheral Interface.

Speed Control Input with Potentiometer

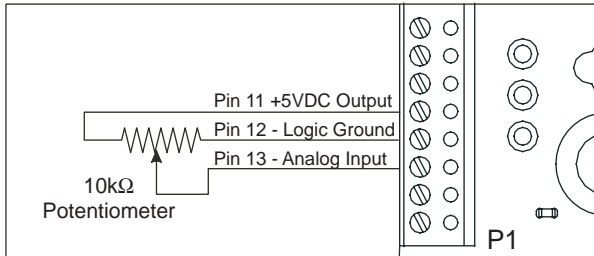

Recommended Potentiometer

Bourns 53AAA-B28-B15. This is available from Digikey (P/N 53AAA-B28-B15-ND) and Newark Electronics (Stock No. 90F6563).

Recommended Parallel/SPI Cable

The recommended method for connecting the Parallel/SPI Communications is the Parameter Setup Cable. Order IMS Part No. OSC-CC100-000.



Parameter Setup Cable Details

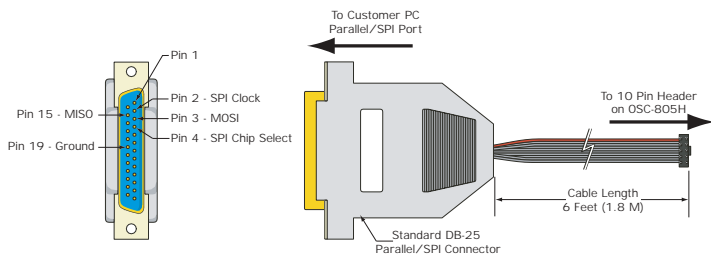

Setup Parameters

SETUP PARAMETERS				
NAME	FUNCTION	RANGE	UNITS	DEFAULT
ACCL	Accel/Decel	2000 to 100000	steps/sec ²	2000
C	Joystick Center	0 to 1022	counts	0
DB	Deadband	0 to 255	counts	1
DCLT	Decel Type	Decel at ACCL Rate/No Decel	-	Decel
MHC	Hold Current	0 to 100	percent	5
MRC	Run Current	1 to 100	percent	25
MSEL	Microstep Resolution	2, 4, 5, 8, 10, 16, 25, 32, 50, 64, 125, 128, 250, 256	μsteps per step	256
RANGE	VI/VM Range	1 to 8	-	3
VI	Initial Velocity	1 to 100000*	steps/sec	400
VM	Maximum Velocity	1 to 100000*	steps/sec	20000

* Depends on the setting of the Range parameter.

For More Information:
See the complete IM805H Product Manual
on the IMS Product CD or at www.imshome.com

Mounting Information

Typical mounting of the IM805H Driver to the OSC-805H Speed Control Board using the HFC-22 Heat Sink/Fan/Clip Assembly.

1) The IM805H Driver plugs into the OSC-805H Speed Control and is secured with two #6-32 screws, lock washers and flat washers.

2) Place the heat sink on the driver and align it so that the dot on the heat sink is on the same side as the dot on the driver. Be certain the TN-22 thermal pad is sandwiched between them.

3) Insert two of the arms from the fan/clip assembly into the corresponding slots in the driver, aligning the curved fingers on the clip between the posts of the heat sink. Insert the other two locking tabs into the opposite slots and snap into place. The locking tabs on all four arms should be completely through the slots on the driver.

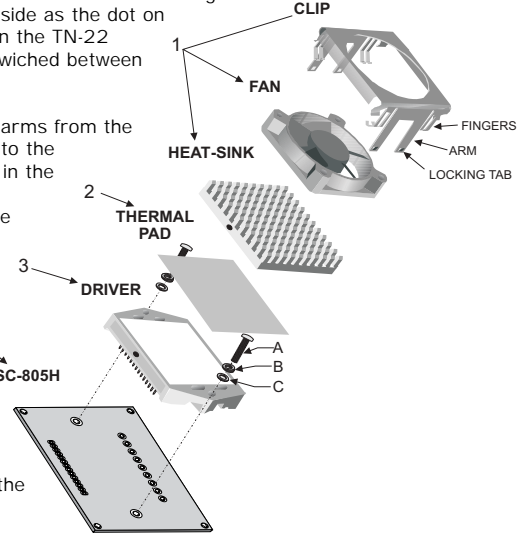

NOTE: The torque specification for the #6-32 mounting screws is 5.0 - 7.0 lbs-in.

Item#	Description	Qty.
1	HFC-22 Heat Sink/Fan/Clip Assembly	1
2	TN-22 Isolating Thermal Pad	1
3	IM805H Microstepping Driver	1
4	OSC-805H Speed Control Board	1
A	#6-32 x 0.625" Pan Head Screw	2
B	#6 Split Lock Washer	2
C	#6 Flat Washer, 0.250" OD, 0.145" ID, 0.030" Thick	2



WARNING! Be certain to remove the clear protective sheet from the TN-22 Thermal Pad before installation.



WARNING! The Heat Sink mounting surface must be a smooth, flat surface with no burrs, protrusions, cuttings or other foreign objects!

Minimum Required Connections

