

MICRO LYNX™ EXPANSION MODULE

ANALOG INPUT/JOYSTICK

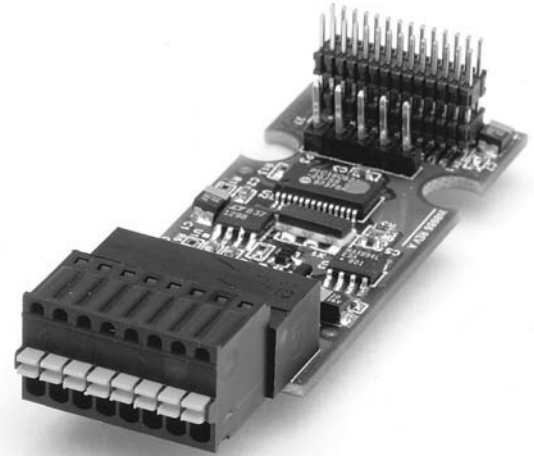

FEATURES

- Low Cost
- Two 0 to +5 VDC Input Channels
- 12 Bit Resolution
- Input Noise Filtering
- Separate Joystick and Calibration References
- Adds the Capability for:
 - Joystick Control
 - Closed Loop Control
 - Data Acquisition
- Plugs Directly into MicroLYNX Controller
- Removable Terminal Strip or Pin Header

DESCRIPTION

The Analog Input/Joystick Interface Module adds two 0 to +5 VDC analog input channels to the MicroLYNX motion control system. Both channels can be used for data acquisition, or either channel may be used to directly control motion.

The user-selected Joystick channel can be programmed to set the range, zero, dead band and sensitivity. A Setup Joystick command is provided to allow the user to easily set up the Joystick parameters.

Each analog channel uses a 12 bit D/A for better resolution as well as a fixed single pole analog filter with a cutoff frequency of 658 Hz to reduce noise that can be present in industrial environments.

PIN ASSIGNMENTS

| PIN | CONNECTOR OPTION | |
|-----|------------------------------|-------------|
| | TERMINAL BLOCK | PIN HEADER |
| 1 | +5V Joystick Reference | REFERENCE |
| 2 | CHANNEL 1 | GROUND |
| 3 | GROUND | CHANNEL 1 |
| 4 | REFERENCE | REFERENCE |
| 5 | CHANNEL 2 | GROUND |
| 6 | GROUND | CHANNEL 2 |
| 7 | 4.096V Calibration Reference | NO CONNECT |
| 8 | GROUND | GROUND |
| 9 | | GROUND |
| 10 | | CALIBRATION |

ELECTRICAL SPECIFICATIONS

| | |
|-----------------------------------------------|---------------|
| Analog Input Voltage Range | 0 to +5 volts |
| Resolution..... | 12 bits |
| Offset..... | ±3 LSB |
| Integral Linearity Error | ±2 LSB |
| Differential Linearity Error | ±3/4 LSB |
| Absolute Maximum Voltage at Inputs | ±24 volts |
| Joystick Reference Voltage..... | +5 volts |
| Calibration Reference Voltage | +4.096 volts |
| Calibration Reference Voltage Tolerance | ±0.2 % |
| Analog Input Filter Cutoff Frequency | 658 Hz |

INTERFACE INFORMATION

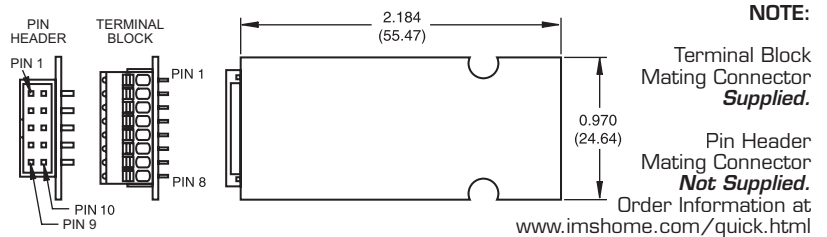

ENVIRONMENTAL

| | |
|----------------------------|-------------------------|
| Storage Temperature | -20 to +70° C |
| Operating Temperature..... | 0 to +50° C |
| Humidity..... | 0 to 90% non-condensing |

ORDER INFORMATION

| | TERMINAL BLOCK | PIN HEADER |
|--------------------|----------------------------|----------------------------|
| PART NUMBER | <i>MX-AJ100-000</i> | <i>MX-AJ200-000</i> |

Standard product shown in bold italics. Lead times may apply to other versions.



INTELLIGENT MOTION SYSTEMS, INC.

Excellence in Motion™

MicroLYNX EXPANSION MODULE

ANALOG INPUT/JOYSTICK MODULE

QUICK REFERENCE



370 N. MAIN ST., PO BOX 457, MARLBOROUGH, CT 06447
PH: (860) 295-6102, FAX: (860) 295-6107
Internet: www.imshome.com, E-Mail: info@imshome.com

Analog Input/Joystick Quick Reference Guide

The primary function of this guide is to acquaint the user with the specifications and configuration of the MicroLYNX Analog Input/Joystick Module. The full MicroLYNX product manual is available in Acrobat PDF format on the IMS Product CD. It also may be downloaded from the IMS web site at www.imshome.com.

Notes And Warnings

Please observe the following when handling, connecting and using your MicroLYNX Expansion Modules. Failure to observe these points may result in damage. All warranty and disclaimer information is located in the full product manual and should be referenced for more information.

 The MicroLYNX Expansion Module components are sensitive to Electrostatic Discharge (ESD). All handling should be done at an ESD protected workstation.

 Hazardous Voltage Levels may be present if using an open frame power supply to power the MicroLYNX Controller and Modules.

 Do not connect or disconnect the AC power or the motor leads with the AC power on.

Mechanical Specifications

Dimensions in Inches (mm)

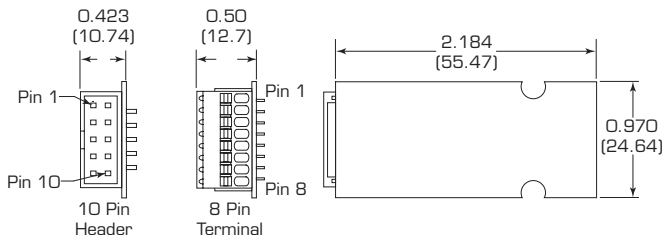

NOTE: The 8 Pin Terminal Block is supplied with the mating connector. The 10 Pin Header is **NOT SUPPLIED** with a mating connector. (Use AMP 3-1437026-4 or equivalent).

Thermal Specifications

| | Range |
|-----------------------------|-------------------------|
| Operating Temperature | 0 to +50°C |
| Storage Temperature | -20 to +70°C |
| Humidity | 0 to 90% non-condensing |

Electrical Specifications

| | |
|-----------------------------------------------|---------------|
| Analog Input Voltage Range | 0 to +5 Volts |
| Resolution | 12 Bits |
| Offset | ±3 LSB |
| Integral Linearity Error | ±2 LSB |
| Differential Linearity Error | ±3/4 LSB |
| Absolute Maximum Voltage at Inputs | ±24 Volts |
| Joystick Reference Voltage | +5 Volts |
| Calibration Reference Voltage | +4.096 Volts |
| Calibration Reference Voltage Tolerance | ±2 % |
| Analog Input Filter Cutoff Frequency | 658 Hz |

Instructions & Variables

The following Instructions and Variables are specific to the Analog Input/Joystick Expansion Module for the MicroLYNX.

| Instruction | Usage | Description |
|-------------|--------------------------------|---------------------------------------------------------------------------------------------------------------------------------------------------------------------------------------------------------------------------------------------------------------------------------------------------------------------------------------------------------------------------------------------------------|
| IJSC | IJSC | CALIBRATE JOYSTICK INSTRUCTION: Supports the Analog/Joystick Interface Module when operating in joystick mode. Execution of this command followed by moving the connected joystick over its range of motion and back to center, and then pressing the "ENTER" key, or letting it time out for 30 seconds calibrates the joystick. This instruction allows for rapid calibration of the joystick. |
| Variable | Usage | Description |
| ADS | ADS<chan>=<aunit>,<func>,<law> | ANALOG INPUT SETUP VARIABLE: Supports the Analog Input/Joystick Module. <chan> = channel # (1 or 2) <aunit> = converts analog units to motor steps (velocity = aunit x munit) <mode> = 1 - analog, 2 - joystick <law> = Adjusts joystick position to motor velocity transformation. 1 = linear, 2 = square law, 3 = cube law |
| AIN | <var>=AIN<chan> | READ ANALOG INPUT CHANNEL: Causes a read of analog input channel <chan>, data is saved as variable <var>. |
| JSC | JSC=<num> | JOYSTICK CENTER POSITION VARIABLE, updated by IJSC command or directly as shown. |
| JSDB | JSDB=<num> | JOYSTICK DEADBAND VARIABLE, updated by ISJC command or directly as shown. |
| JSFS | JSFS=<num> | JOYSTICK FULL SCALE VARIABLE, updated by ISJC command or directly as shown. |
| Flag | Usage | Description |
| JSE | JSE=<flg> | JOYSTICK ENABLE FLAG: <flg> = 1 enables joystick function, <flg> = 0 (default) disables. |

Error Codes

In addition to the Instructions and Variables, the following error codes have been added to support the inclusion of the Analog Input/Joystick Expansion Module and aid in troubleshooting the MicroLYNX System:

- 1201 Selected Analog Board not installed.
- 1202 Analog channel number not available.
- 1204 Analog option not installed.
- 1205 Analog VALUE out of range, possibly defective Board.
- 2101 Analog RANGE not allowed.
- 2102 Analog destination/source not allowed.
- 2103 Analog Destination/Source already used.
- 2104 Invalid Analog Channel number.
- 2105 Analog LAW not allowed.
- 2106 Can't enable Joystick while in motion, or can't exec motion cmd with Joystick enabled.
- 9014 Analog input not allowed for data.

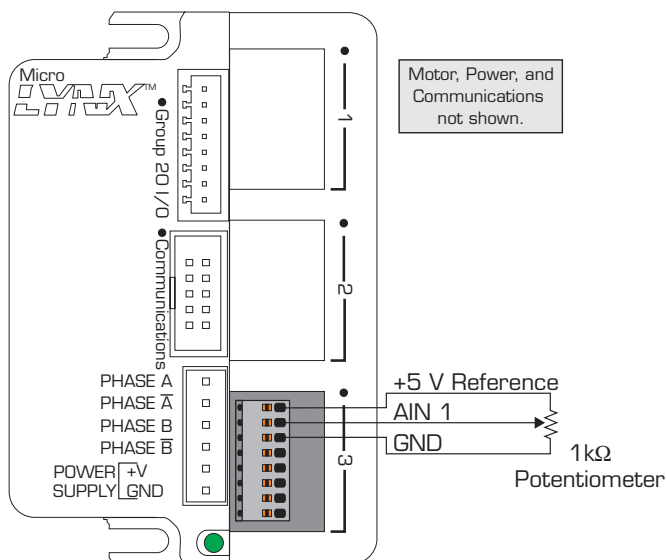

| Pin # | Connector Option | |
|-------|-----------------------------------|-----------------------------------|
| | 8 Pin Terminal Block | 10 Pin Header |
| 1 | +5 Volt Reference | +5 Volt Reference |
| 2 | Channel 1 | Ground |
| 3 | Ground | Channel 1 |
| 4 | +5 Volt Reference | +5 Volt Reference |
| 5 | Channel 2 | Ground |
| 6 | Ground | Channel 2 |
| 7 | +4.096 Volt Calibration Reference | NC |
| 8 | Ground | Ground |
| 9 | | Ground |
| 10 | | +4.096 Volt Calibration Reference |

MicroLYNX Slot Usage

The Analog Input/Joystick Expansion Module may be used in any expansion slot in the MicroLYNX, with a maximum of one Module per MicroLYNX.

| MicroLYNX Expansion Slot Usage | | | | |
|--------------------------------|------------|------------|------------|-----------------|
| Expansion Module | Slot 1 | Slot 2 | Slot 3 | Maximum Allowed |
| Isolated Digital I/O | Yes | Yes | Yes | 3 |
| High Speed Differential I/O | No | Yes | Yes | 2 |
| Analog Input/Joystick | Yes | Yes | Yes | 1 |
| Isolated Communication | No | Yes | No | 1 |
| Analog Output | Yes | Yes | Yes | 2 |
| 12 Channel I/O | Yes | Yes | No | 1 |

Exercise 1: Velocity (Joystick) Mode

The potentiometer is emulating a joystick. Enter and execute the following program. When the voltage on AIN 1 is approximately 100mV under or over 2.5 volts it will be in the deadband range of the joystick. When AIN 1 is less than 2.4 volts, the axis will accelerate in the minus [-] direction. When AIN 1 is greater than 2.6 volts, the axis will accelerate in the positive [+] direction. The velocity will increase as the voltage increases or decreases. This can be seen with a multimeter. In this exercise both the axis velocity and position will display to the terminal screen.

```

*****Parameters*****
MSEL=256
MRC=100
MAC=100
MUNIT=51200
JSDB=100           'Joystick deadband =100 aunits
VM =10000         'max velocity 10,000 ununits/sec
ADS 1=1000,2,1   'chan. 1,aunits=1000, joystick, linear law
JSE = 1          'enable joystick functions

*****Program*****

PGM 1
PRINT "\_e[2J"
LBL RUN
PRINT "\_e[1;1HInput Channel = ",AIN
PRINT "Axis Velocity = ",VEL
PRINT "Axis Position = ",POS
BR RUN
END
PGM
    
```

Exercise 2: Sensor Input 1

The potentiometer is emulating a pressure transducer to display a pressure value to the screen.

```

ADS 1=50.5,1      'set ADS to aunit=50.5,analog input mode

PGM 200
LBL PRNTPSI      'name program "PRNTPSI"
PRINT "\_e[2J"  'ansi esc. sequence to clear display
PRINT "Pressure = ",AIN 1,"PSI"
BR PRNTPSI      'loop to program beginning
END
PGM
    
```

Installing the Analog Input/Joystick Module

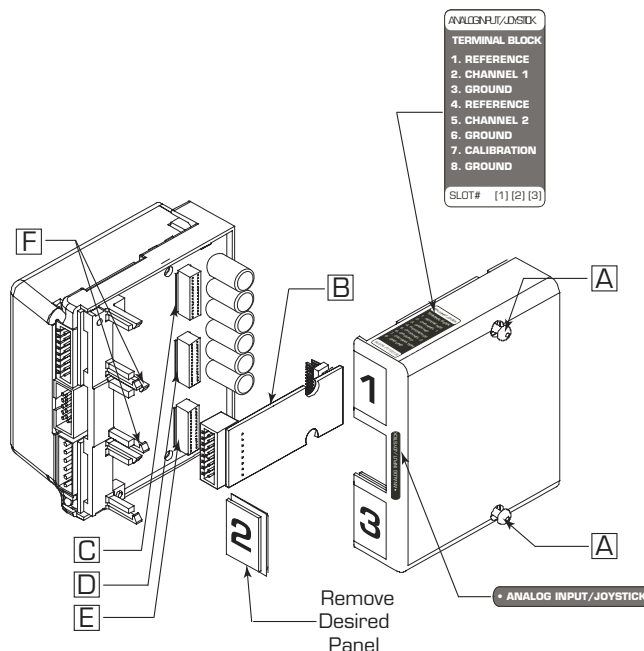

To Install the Module:

- 1) Remove the two retaining screws (A) from the cover.
- 2) Remove the blank panel (1, 2, or 3) from the desired slot you want to use.
- 3) Carefully press the Expansion Module (B) into place by plugging the 28 pin connector into the desired receptacle (C, D, or E) and snapping it into place under the retaining clips (F).
- 4) Reinstall the MicroLYNX cover.
- 5) Affix the labels supplied with the Module as shown.

For More Information:
 See the complete LYNX Product Family Operating Manual on the IMS Product CD or at www.imshome.com