

# Quick Reference MDrive® 34AC Microstepping



## Notes and Warnings

Installation, configuration and maintenance must be carried out by qualified technicians only. You must have detailed information to be able to carry out this work. This information can be found in the user manual.

- Unexpected dangers may be encountered when working with this product!
- Incorrect use may destroy this product and connected components!

The user manual is not included, but may be obtained from the Internet at: <http://www.imshome.com/downloads/manuals.html>.

## Required for Setup\*

- PC running Microsoft® Windows XP Service Pack 2 or greater.
- SPI Motor Interface (available online).
- MD-CS200/201-000 or equivalent Lumberg mating connector/cordset for AC power.
- 0 to 5 MHz clock signal for step clock, may be a controller high speed output or signal generator.
- SPST switch or controller I/O point to control axis direction.
- I/O and SPI communications interface (recommended: MD-CC301-001).

\* If you purchased your MDrive with a QuickStart Kit, you have received all of the connecting cables needed for initial functional setup and system testing.

## Getting Started

All documentation, software and resources are available online at: [http://www.imshome.com/products/mdrive\\_motor\\_driver.html](http://www.imshome.com/products/mdrive_motor_driver.html).

## Connecting Power and I/O

Your MDrive is configured with power and I/O on separate connectors. Please refer to the opposite side of this document for connecting details and available connectivity recommendations.

## Connecting Communications

1. Connect IMS USB to SPI communications converter to MDrive and PC.
2. Install the communication converter drivers onto PC (available online).
3. Install and open SPI Motor Interface.
4. Apply power to MDrive.
5. Parameters may be adjusted via two screens, the Motor Settings screen or the I/O Settings screen (shown below), accessible via the View menu.

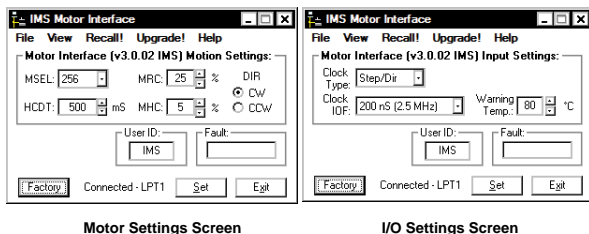

## Specifications

Electrical Specifications	
Input Voltage Range (120 VAC MDrive)	95 to 132 VAC @ 50/60 Hz
Input Current (120 VAC MDrive)	4.2 Amps
Input Voltage Range (240 VAC MDrive)	95 to 264 VAC @ 50/60 Hz
Input Current (240 VAC MDrive)	2.1 Amps

Environmental Specifications		
Operating Temperature (non-condensing)	Heat Sink	-40°C to +75°C
	Motor	-40°C to +90°C
Sealing (IP65 versions only)		IP65 Compliant

Isolated Input Specifications	
<b>Step Clock, Direction and Enable</b>	
Voltage Range (Sinking or Sourcing)	+5 to +24 VDC
Current (+5V Max)	8.7 mA
Current (+24V Max)	14.6 mA

Motion Specifications	
Digital Filter Range	50 nS to 12.9 µS (10 MHz to 38.8 kHz)
Clock Types	Step/Direction, Up/Down, Quadrature
Step Frequency (Max)	5 MHz
Step Frequency Minimum Pulse Width	100 nS
Number of Microstep Resolution Settings	20

Available Microsteps Per Revolution									
200	400	800	1000	1600	2000	3200	5000	6400	10000
12800	20000	25000	25600	40000	50000	51200	36000 <sup>1</sup>	21600 <sup>2</sup>	25400 <sup>3</sup>

1=0.01 deg/µstep    2=1 arc minute/µstep    3=0.001 mm/µstep

Protection Specifications	
Thermal	
Internal Fuse (Line-Neutral Systems Only, Line-Line Systems Require External Fusing)	

Temp. Warning Output Specifications	
Type	Open Drain
Drain-Source Voltage	+5 to +24 VDC
Drain Current	50 mA

## Setup Parameters

Setup Parameters				
Name	Function	Range	Units	Default
MHC	Motor Hold Current	0 to 100	Percent	5
MRC	Motor Run Current	1 to 100	Percent	25
MSEL	Microstep Resolution	See Motion Specifications	µsteps/Full Step	256
DIR	Motor Direction Override	0/1	—	CW
HCdT	Hold Current Delay Time	0 or 2 - 65535	mSec	500
CLK TYPE	Clock Type	See Motion Specifications	—	Step/Direction
CLK IOF	Clock Input Filter	50 nS to 12.9 µS (10 MHz to 38.8 kHz)	nS (MHz)	200 nS (2.5MHz)
EN ACT	Enable Active High/Low	High/Low	—	High
USER ID	User ID	3 Characters Viewable ASCII	Viewable ASCII	IMS
WARN TEMP	Over Temperature Warning	0 to 125	°C	80

## Mechanical Specifications

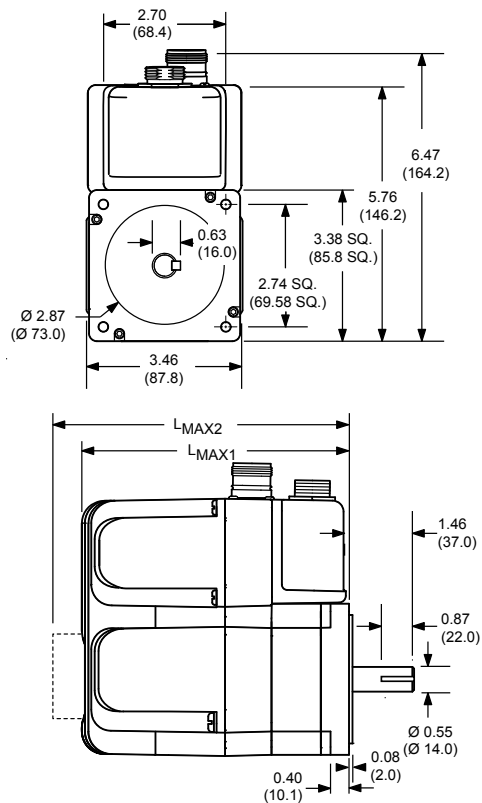

Motor Length	Dimensions in inches (mm)	
	LMAX1 (Single Shaft or Internal Encoder)	LMAX2 (Control Knob)
Single	6.1 (155.0)	7.1 (180.4)
Double	6.9 (174.3)	7.9 (199.7)
Triple	8.4 (214.3)	9.4 (239.79)

# MDrive 34AC Microstepping Connectivity Options

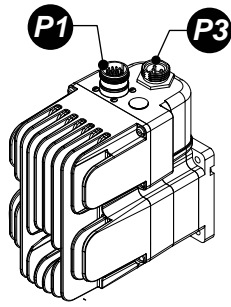

Connector Style	Function
<b>P1</b> 19-pin M23 circular.....	I/O, Communications and Encoder
<b>P3</b> 3-pin Euro AC.....	Power

## **P1** I/O, Communications and Optional Internal Encoder

19-pin M23 circular connector (male)

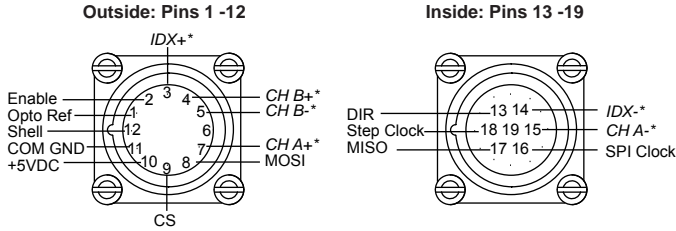

\*No Connect unless populated for the optional internal magnetic differential encoder

## **P3** AC Power

3-pin Euro AC connector (male)

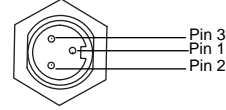

### Prototype Development Cordset

p/n (straight connector): MD-CS200-000  
p/n (right-angle connector): MD-CS201-000

Pre-wired mating connector interfaces to an MDrive's 3-pin circular EuroAC connector, with flying leads other end, for quick test/development.

Note that this cable or equivalent Lumberg mating connector/cable must be used to meet UL conditions of acceptability.

### Communications Converter p/n: MD-CC301-001

Electrically isolated in-line USB to SPI converter with mating connector to conveniently program and set configuration parameters. A secondary cable from the mating connector provides interface to power and I/O.

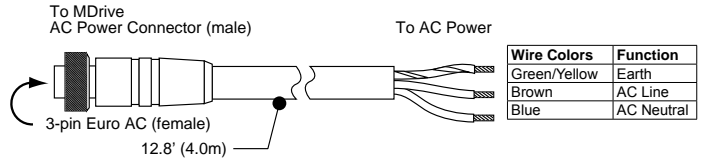
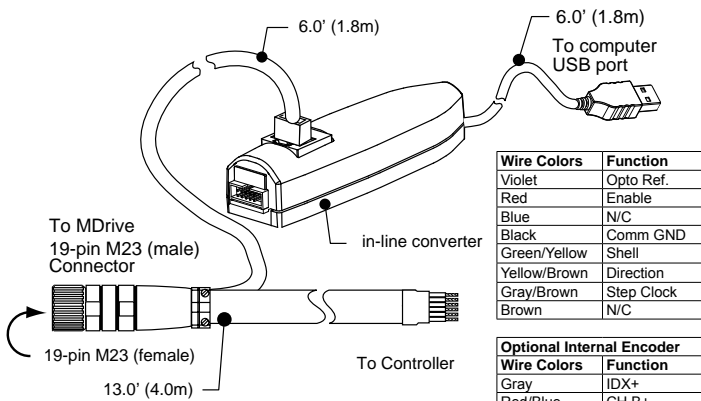

### Mating Connector Recommendations

The following field-solderable mating connector is recommended for use with the MDrive AC. Use of this connector meets UL Acceptability requirements.

Lumberg: RKC 30/11

### Minimum Required Connections

The diagrams below represent the minimum connections required to operate the MDrive Microstepping.

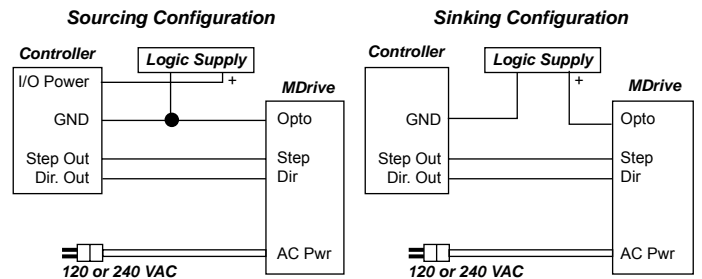

### Prototype Development Cordset p/n: MD-CS100/101-000

Speed test and development with pre-wired mating connector.

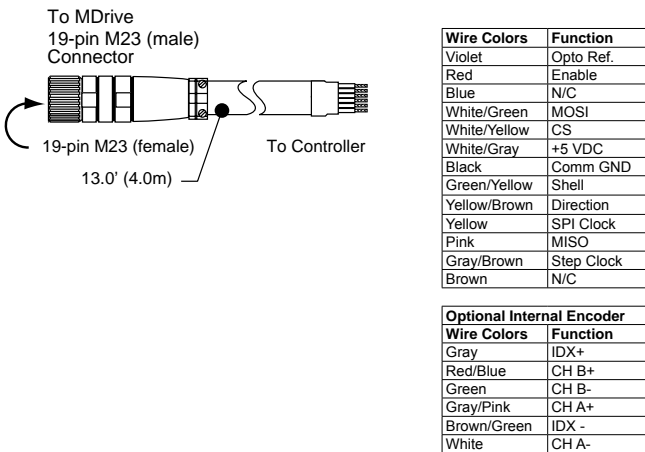

### Mating Connector Recommendations

The MD-CS100-000 is recommended with 19-pin M23 connector.

For comparable connector only, shop vendors:

- Lumberg
- Phoenix
- Turck
- RDE Connectors

### UL Conditions of Acceptability



When used in end-product equipment, the following are among the considerations to be made:

The temperature tests were conducted with the device's face mounted to an aluminum heat sink. For devices with the frame designation 34, the dimensions for the heat sink were 10" x 10" x 1/4". The shaft was also provided with aluminum wheels, approximately 4" in diameter and 1/4" thick.

These devices are intended for installation in a Pollution Degree 2 (controlled) environment. Suitability of the spacings shall be considered in end-use application.

The enclosure of this device is intended as the final end-use enclosure.

These devices do not provide motor overload protection.

These devices have not been subjected to the short circuit test. This test shall be considered in the end-product investigation.

The following MDrive AC products are excluded from UL Recognition:



- MDrive AC models with a rear motor shaft extension, i.e. Control Knob versions.