



intelligent motion systems, inc.
Excellence in Motion™

INT-483H/805H

INTERFACE BOARD FOR THE IM483H/IM805H DRIVER

QUICK REFERENCE



370 N. MAIN ST., PO BOX 457, MARLBOROUGH, CT 06447
PH: (860) 295-6102, FAX: (860) 295-6107
Internet: www.imshome.com, E-Mail: info@imshome.com

INT-483H/805H Quick Reference Guide

The primary function of this Quick Reference Guide is to acquaint the user with the specifications, basic wiring and configuration of the INT-483H/805H Interface Board for the IM483H/IM805H Driver. More information is available on these products in the full IM483H/IM805H product manual saved in Acrobat PDF format on the IMS Product CD, shipped with the product. It also may be downloaded from the IMS web site at <http://www.imshome.com>.

Notes And Warnings

Please observe the following when handling, connecting and using your INT-483H/805H Interface Board. Failure to observe these points may result in damage to the Interface Board or the IM483H/IM805H Driver. All warranty and disclaimer information is located in the full product manual on the CD and should be referenced for more information.

WARNING! The INT-483H/805H Interface Board and IM483H/IM805H Driver components are sensitive to Electrostatic Discharge (ESD). All handling should be done at an ESD protected workstation.

WARNING! Hazardous Voltage Levels may be present if you are using an open frame power supply to power the INT-483H/805H Interface Board and IM483H/IM805H Driver.

WARNING! Ensure that the Power Supply output voltage does not exceed the maximum input voltage of the IM483H/IM805H Driver.

WARNING! Do not operate the IM483H/IM805H Driver without a Current Adjustment Resistor! If you are installing the INT-483H/805H Interface Board the resistors may be added to it.

A resistor **MUST** be placed between the Current Adjust Input (Pin 4) and ground (Pin 3) to keep the IM483H/IM805H Driver, the INT-483H/805H Interface Board and/or motor in a safe operating range.

WARNING! Do not connect or disconnect the motor leads or the AC power supply with power applied.

Please see the motor and driver documentation for other warnings and notes.

Electrical Specifications *

	MIN	TYP	MAX	UNIT
Opto Supply				
Isolated Inputs	+5		+40	V
Input Forward Current				
Isolated Inputs	8	10	12	mA
Opto Input Forward Voltage				
Isolated Inputs	1.5	1.7		V
Reverse Breakdown Voltage				
Isolated Inputs	5			V
Signal Output Current				
Full Step, Fault		25		mA
Drain Source Voltage				
Full Step, Fault		100		V
Drain Source Resistance				
Full Step, Fault, $I_{DS} = 25\text{mA}$	6.5			Ω

* All test data was taken at 25°C and +V = 45 VDC.

For More Information:
See the complete IM483H/IM805H Product Manual on the IMS Product CD or at www.imshome.com

INT-483H/805H P1 Connector Pin Assignment

Connector P1: 10 Position Phoenix		
Pin #	Pin Name	Description
1	Opto Supply	+5 to +24VDC
2	Current Reduction	Phase Current Reduction Input
3	Current Adjust	Phase Current Adjust Input
4	GND	Ground
5	Reset	Active LOW Reset Input
6	Enable	Active HIGH Motor Phase Enable Input
7	Direction	Motor Direction Input
8	Step Clock	Motor Step Clock Input
9	Full Step	Open Drain on Full Step Output
10	Fault	Open Drain Fault Output
Connector P2: 7 Pin Screw Terminal		
Pin #	Pin Name	Description
1&2	Phase A	Phase A Output
3&4	Phase B	Phase B Output
5, 6	Ground	Supply Voltage Ground (return)
7	+V	Motor Supply Voltage Input

Output Current Adjust/Current Reduction *

The INT-483H/805H utilizes the IM483H/IM805H internal current source to adjust the Output Current. To calculate both the Run Current and the Reduced Current** (hold) refer to the IM483H/IM805H instruction manual. The figure below shows the resistor connections for both Run and Hold Current.

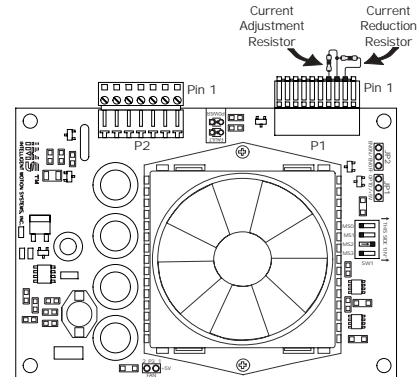

* When connecting both the current reference and current reduction resistors, make the connections as short as possible to minimize the noise coupled into the driver.

** **WARNING! DO NOT** install the Current Reduction resistor when the JP2 jumper is in the "ENON" position. See JP2 under "Isolated Inputs".

Isolated Inputs

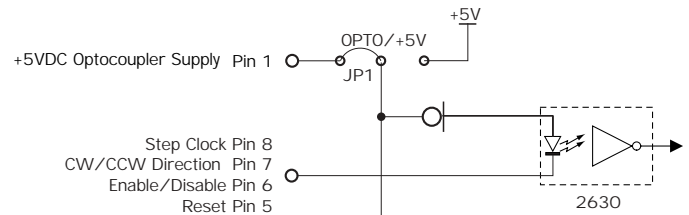

Typical Opto Isolated Inputs

JP1: If the shunt is placed on the "OPTO" side of the jumper the power for the Opto Isolators must be provided by the user at Pin 1 on the P1 connector. If the shunt is placed on the "+5V" side of the jumper then the Opto Isolators will be powered by the on-board supply and electrical isolation between the inputs and the drive power will be eliminated.

JP2: If the shunt is placed on the "ENON" side of the jumper then the drive outputs will be automatically disabled approximately 0.5 seconds after the last Step Clock Input.

NOTE: In this mode the Current Reduction Resistor **MUST NOT** be used or it will cause erratic operation of the driver. If the shunt is placed on the "ENOFF" side of the jumper then a Current Reduction Resistor can be used to set the level of current in the motor after the last step clock input.

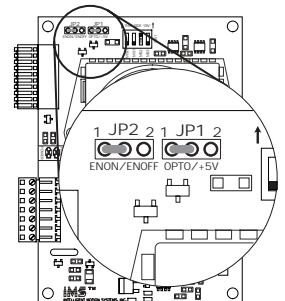

JP1 and JP2 Jumpers

LED Indicators

The green LED is controlled by the on-board +5VDC power supply.

The red LED is controlled by the Fault Output of the IM483H/IM805H. If the red LED is illuminated turn off power and check for a system fault.

A fault may be caused by a short or incorrect wiring of the motor or power supply. A fault condition can only be reset by cycling power or toggling of the Reset Input on P1 Pin 5. In the case of an over temperature fault allow the drive to cool before re-applying power.

Fault Protection

The INT-483H/805H adds phase to ground fault protection to the IM483H/IM805H. If a phase to ground fault is detected the Driver will latch the signal, set the Fault Output and illuminate the red Fault LED. To clear the fault condition, the Driver will have to be Reset or power will need to be cycled.

The INT-483H/805H buffers the IM483H/IM805H Fault Output signal through an open drain N-channel FET. The signal at the terminal strip is inverted and is active LOW.

In the case of an over temperature fault, neither the red LED or the Fault Output become activated. The IM483H/IM805H motor outputs will disable. They will not re-enable until the drive cools to a safe operating level.

Full Step Output

The INT-483H/805H buffers the IM483H/IM805H Full Step Output through an open drain N-channel FET. The signal available at the terminal strip is inverted and is active low. Reset or Power Up = Full Step.

Recommended Wiring

Logic level cables must not run parallel to power cables. Power cables will introduce noise into the logic level cables and make your system unreliable.

Logic level cables must be shielded to reduce the chance of EMI induced noise. The shield needs to be grounded at the signal source to AC ground. The other end of the shield must not be tied to anything, but allowed to float. This allows the shield to act as a drain.

Motor cabling in excess of 1 foot requires twisted pair shielded cable to reduce the transmission of EMI. The shield must be connected to AC ground at the driver. The other end of the shield must not be tied to anything, but allowed to float. This allows the shield to act as a drain.

Power supply leads to the driver need to be twisted. If more than one driver is to be connected to the same power supply, run separate power and ground leads from the supply to each driver.

Refer to the IM483H/IM805H operating instructions for recommended motor and power supply cables.

Microstep Resolution Selection

Resolution		Microstep Select DIP Switch Settings			
Microsteps/Step	Steps/Rev	SW 1:1 (MSEL0)	SW 1:2 (MSEL1)	SW 1:3 (MSEL2)	SW 1:4 (MSEL3)
Binary Microstep Resolution Settings (1.8° Motor)					
2	400	ON	ON	ON	ON
4	800	OFF	ON	ON	ON
8	1,600	ON	OFF	ON	ON
16	3,200	OFF	OFF	ON	ON
32	6,400	ON	ON	OFF	ON
64	12,800	OFF	ON	OFF	ON
128	25,600	ON	OFF	OFF	ON
256	51,200	OFF	OFF	OFF	ON

Decimal Microstep Resolution Settings (1.8° Motor)					
5	1,000	ON	ON	ON	OFF
10	2,000	OFF	ON	ON	OFF
25	5,000	ON	OFF	ON	OFF
50	10,000	OFF	OFF	ON	OFF
125	25,000	ON	ON	OFF	OFF
250	50,000	OFF	ON	OFF	OFF

Invalid Resolution Settings: May Cause Erratic Operation					
		ON	OFF	OFF	OFF
		OFF	OFF	OFF	OFF

In the above table ON is ground and OFF is floating.

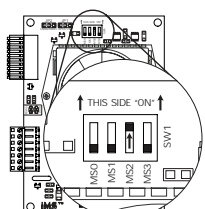

The number of microsteps per step is selected by the dip switch (SW1). The above table shows the standard resolution values along with the associated switch settings.

MSEL Switch Shows 50 Microsteps/Step Selected

Mechanical Specifications

Dimensions in Inches (mm)

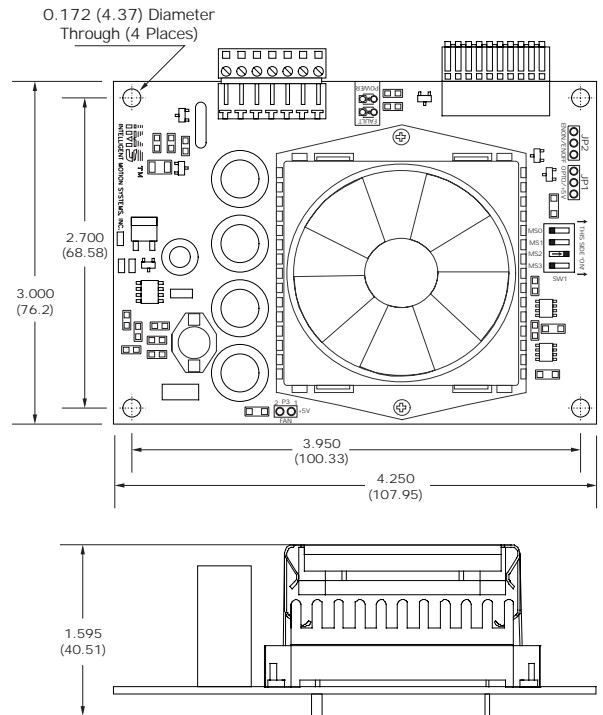

Mounting Information

Typical mounting of the IM483H/805H Driver to the INT483H/805H Interface Board using the IM483H/805H Developer's Kit.

1) The IM483H/805H Driver is mounted to the INT483H/805H Interface Board with two #6-32 screws, lock washers and flat washers.

NOTE: The torque specification for the #6-32 INT-483H/805H and IM483H/IM805H mounting screws is 5.0 - 7.0 lbs-in.

2) Place the heat sink on the driver and align so that the dot on the heat sink is on the same side as the dot on the driver. Be certain the TN-22 thermal pad is sandwiched between them.

3) Insert two of the arms from the fan/clip assembly into the corresponding slots in the driver, aligning the curved fingers on the clip between the posts of the heat sink.

Insert the other two locking tabs into the opposite slots and snap into place. The locking tabs on all four arms should be completely through the slots on the driver.

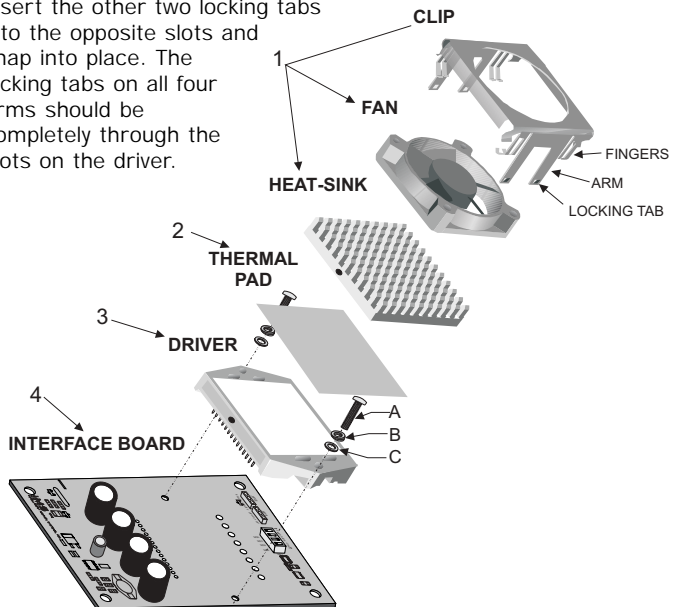

WARNING! Be certain to remove the clear protective sheet from the TN-22 Thermal Pad before installation.

WARNING! The Heat Sink mounting surface must be a smooth, flat surface with no burrs, protrusions, cuttings or other foreign objects!

Developer's Kit Parts List

Item#	Description	Qty.
1	HFC-22 Heat Sink/Fan/Clip Assembly	1
2	TN-22 Isolating Thermal Pad	1
3	IM483H/IM805H Microstepping Driver	1
4	INT-483H/805H Interface Board	1
A	#6-32 x 0.625" Pan Head Screw	2
B	#6 Split Lock Washer	2
C	#6 Flat Washer, 0.250" OD, 0.145" ID, 0.030" Thick	2