



intelligent motion systems, inc.
Excellence in Motion™

INT-481

INTERFACE BOARD FOR THE IM481H DRIVER

QUICK REFERENCE

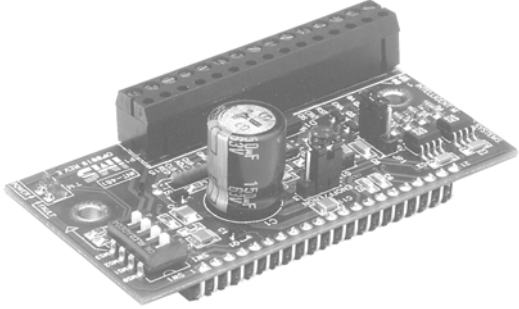

370 N. MAIN ST., PO BOX 457, MARLBOROUGH, CT 06447
PH: (860) 295-6102, FAX: (860) 295-6107
Internet: www.imshome.com, E-Mail: info@imshome.com

INT-481 Quick Reference Guide

The primary function of this Quick Reference Guide is to acquaint the user with the specifications, basic wiring and configuration of the INT-481 Interface Board for the IM481H Driver. More information is available on both products in the full IM481H product manual saved in Acrobat PDF format on the IMS Product CD, shipped with the product. It also may be downloaded from the IMS web site at <http://www.imshome.com>.

Notes And Warnings

Please observe the following when handling, connecting and using your INT-481 Interface Board. Failure to observe these points may result in damage to the Interface Board or the IM481H Driver. All warranty and disclaimer information is located in the full product manual on the CD and should be referenced for more information.



WARNING! The INT-481 Interface Board and IM481H Driver components are sensitive to Electrostatic Discharge (ESD). All handling should be done at an ESD protected workstation.



WARNING! Hazardous Voltage Levels may be present if you are using an open frame power supply to power the INT-481 Interface Board and IM481H Driver.



WARNING! Ensure that the Power Supply output voltage does not exceed the maximum input voltage of the IM481H Driver.



WARNING! Do not operate the IM481H Driver without a Current Adjustment Resistor! If you are installing the INT-481 Interface Board the resistors may be added to it.

A resistor **MUST** be placed between the Current Adjust Input (Pin 14) and ground (Pin 13) to keep the IM481H Driver, the INT-481 Interface Board and/or motor in a safe operating range.



WARNING! Do not connect or disconnect the motor leads or the AC power supply with power applied.

Please see the motor and driver documentation for other warnings and notes.

Electrical Specifications*

	MIN	TYP	MAX	UNIT
Opto Supply				
Isolated Inputs	+5		+40	V
Input Forward Current				
Isolated Inputs	5		15	mA
Opto Input Forward Voltage				
Isolated Inputs	1.5		1.7	V
Reverse Breakdown Voltage				
Isolated Inputs	5			V
Signal Output Current				
Full Step, Fault			20	mA
Drain Source Voltage				
Full Step, Fault			100	V
Drain Source Resistance				
Full Step, Fault, $I_{DS} = 25\text{mA}$	6.5			Ω

* All test data was taken at 25°C and +V = 45 VDC.

For More Information:
See the complete IM481H Product Manual
on the IMS Product CD or at www.imshome.com

INT-481 P1 Connector Pin Assignment

Pin #	Pin Name	Description
1	Phase B	Phase B Output
2	Phase B	Phase B Output
3	Phase A	Phase A Output
4	Phase A	Phase A Output
5	Enable	When this input is HIGH, motor phases are energized.
6	Reset	When LOW, this input will Reset the Driver.
7	Opto Supply	+5 to +24 VDC external Optocoupler power supply.
8	Direction	This input changes the direction of the motor. The physical direction depends on the connection of the motor windings.
9	Step Clock	A positive going edge on this input advances the motor one increment. The size of the increment is dependent on the Microstep Select Inputs.
10	Fault	This Output indicates a short circuit has occurred or a low was detected on the Fault Input. This Output is active HIGH.
11	Full Step	This Output indicates when the driver positions the motor one Full Step. This output can be used to count the number of Full Steps the motor has moved regardless of the number of Microsteps. This output is active HIGH.
12	+V	+12 to +48 VDC Motor Power Supply.
13	Ground	Power Supply Ground.
14	Current Adjust	Phase Current Adjustment Input. A voltage applied to this Input sets the peak Phase Current of the motor.
15	Current Reduction	Phase Current Reduction Input. A resistor connected between this pin and Pin 14 (if used to set motor current) will proportionately reduce the current in both windings approximately 0.5 seconds after the last positive edge of the Step Clock Input.

Output Current Adjust/Current Reduction*

The INT-481 utilizes the IM481H's internal current source to adjust the Output Current of the IM481H. To calculate both the Run Current and the Reduced Current** (hold) refer to the IM481H instruction manual. The figure below shows the resistor connections for both run and hold currents.

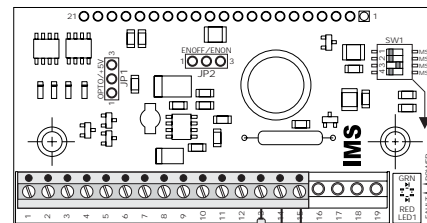

Current Adjust Resistor 1/8 W 1% Ω Reduction Adjust Resistor 1/8 W 1% Ω
Pin 13 Pin 14 Pin 15

* When connecting both the current reference and current reduction resistors, connections should be made as short as possible to minimize the noise coupled into the driver.

** **WARNING! DO NOT** install the Current Reduction resistor when the JP2 jumper is in the "ENON" position. See JP2 under "Isolated Inputs".

Isolated Inputs

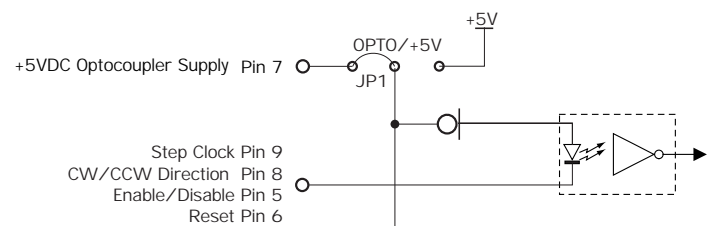

Typical Opto Isolated Inputs

JP1: If the shunt is placed on the "OPTO" side of the jumper the power for the Opto Isolators must be provided by the user at Pin 7 on the P1 connector. If the shunt is placed on the "+5V" side of the jumper then the Opto Isolators will be powered by the on-board supply and electrical isolation between the inputs and the drive power will be eliminated.

JP2: If the shunt is placed on the "ENON" side of the jumper then the drive outputs will be automatically disabled approximately 0.5 seconds after the last step clock input.

NOTE: In this mode the current reduction resistor **MUST NOT** be used or it will cause erratic operation of the driver. If the shunt is placed on the "ENOFF" side of the jumper then a current reduction resistor can be used to set the level of current in the motor after the last step clock input.

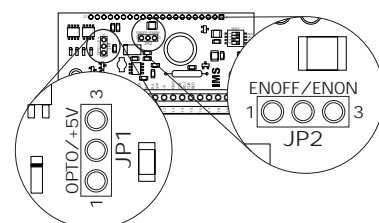

JP1 And JP2 Jumpers

LED Indicators

The green LED is controlled by the on-board +5VDC power supply.

The red LED is controlled by the Fault Output of the IM481H. If the red LED is illuminated turn off power and check for a system fault.

A fault may be caused by a short or incorrect wiring of the motor or power supply. A fault condition can only be reset by cycling power or toggling of the Reset Input on P1 Pin 6. In the case of an over temperature fault allow the drive to cool before re-applying power.

Fault Protection

The INT-481 adds phase to ground fault protection to the IM481H. If a phase to ground fault is detected the IM481H will latch the signal, set the Fault Output and illuminate the red Fault LED. To clear the fault condition, the IM481H will have to be Reset or power will need to be cycled.

The INT-481 buffers the IM481H Fault Output signal through an open drain N-channel FET. The signal at the terminal strip is inverted and is active LOW.

In the case of an over temperature fault, neither the red LED or the Fault Output become activated. The IM481H's motor outputs will disable. They will not re-enable until the drive cools to a safe operating level.

Full Step Output

The INT-481 buffers the IM481H Full Step Output through an open drain N-channel FET. The signal available at the terminal strip is inverted and is active low. Reset or Power Up = Full Step.

Recommended Wiring

Logic level cables must not run parallel to power cables. Power cables will introduce noise into the logic level cables and make your system unreliable.

Logic level cables must be shielded to reduce the chance of EMI induced noise. The shield needs to be grounded at the signal source to AC ground. The other end of the shield must not be tied to anything, but allowed to float. This allows the shield to act as a drain.

Motor cabling in excess of 1 foot requires twisted pair shielded cable to reduce the transmission of EMI. The shield must be connected to AC ground at the driver. The other end of the shield must not be tied to anything, but allowed to float. This allows the shield to act as a drain.

Power supply leads to the driver need to be twisted. If more than one driver is to be connected to the same power supply, run separate power and ground leads from the supply to each driver.

Refer to the IM481H operating instructions for recommended motor and power supply cables.

Microstep Resolution Selection

The number of microsteps per step is selected by the dip switch (SW1). The following table shows the standard resolution values along with the associated switch settings.

Resolution		Microstep Select DIP Switch Settings			
Microstep/Step	Steps/Rev	SW 1:1 (MSEL0)	SW 1:2 (MSEL1)	SW 1:3 (MSEL2)	SW 1:4 (MSEL3)
Binary Microstep Resolution Settings (1.8° Motor)					
2	400	ON	ON	ON	ON
4	800	OFF	ON	ON	ON
8	1,600	ON	OFF	ON	ON
16	3,200	OFF	OFF	ON	ON
32	6,400	ON	ON	OFF	ON
64	12,800	OFF	ON	OFF	ON
128	25,600	ON	OFF	OFF	ON
256	51,200	OFF	OFF	OFF	ON

Decimal Microstep Resolution Settings (1.8° Motor)					
5	1,000	ON	ON	ON	OFF
10	2,000	OFF	ON	ON	OFF
25	5,000	ON	OFF	ON	OFF
50	10,000	OFF	OFF	ON	OFF
125	25,000	ON	ON	OFF	OFF
250	50,000	OFF	ON	OFF	OFF

Invalid Resolution Settings: May Cause Erratic Operation					
		ON	OFF	OFF	OFF
		OFF	OFF	OFF	OFF

In the above table ON is ground and OFF is floating.

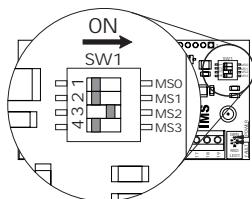

MSEL Switch Shows 50 Microsteps/Step Selected

Mechanical Specifications

Dimensions in Inches (mm)

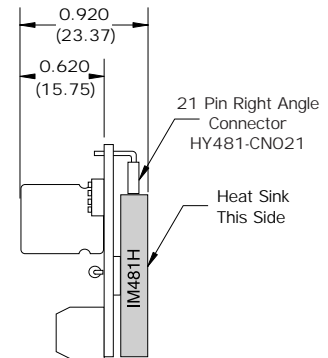
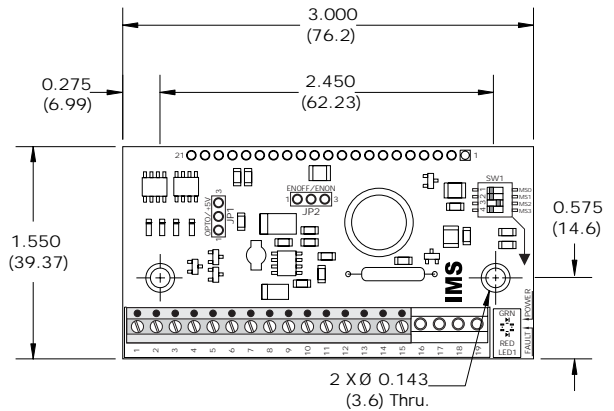

Mounting Information

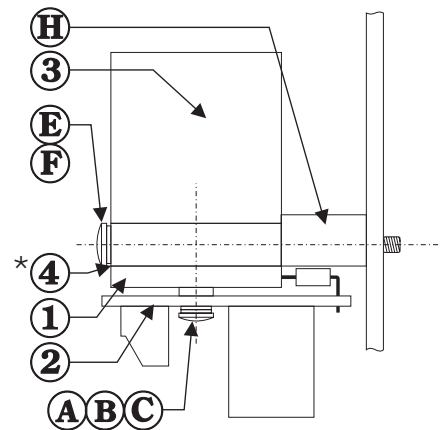

INT-481 Interface Board with IM481H Driver and H-481 Heat Sink

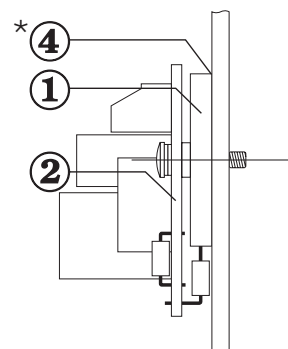

INT-481 Interface Board and IM481H Driver
Panel Mounted without H-481 Heat Sink

* The Isolating Thermal Pad (TI-481) Item #4 is supplied with the Interface Board.



WARNING! The Heat Sink mounting surface must be a smooth, flat surface with no burrs, protrusions, cuttings or other foreign objects!

Mounting Parts List * *

Item #	Description	Qty.
1	IM481H Microstepping Driver	1
2	INT-481 Interface Board	1
3	H-481 Heat Sink	1
4	TI-481 Isolating Thermal Pad	1
A	#6-32 x 0.625" Pan Head Screw	2
B	#6 Split Lock Washer	2
C	#6 Flat Washer, 0.250" OD, 0.145" ID, 0.030" Thick	2
E	#8-32 x 2" Pan Head Screw	2
F	#8 Split Lock Washer	2
H	Spacer, 0.312" OD, 0.171" ID, 0.500" L	2

* * The hardware Items A, B, C, E, F, H, are supplied with the H-481 Heat Sink Kit but not with the INT-481 Interface Board.

NOTE: The torque specification for the #6-32 INT-481 and IM481H mounting screws is 5.0 - 7.0 lbs-in.