

# IM481H Plus

ULTRA MINIATURE HIGH PERFORMANCE MICROSTEPPING DRIVER



## QUICK REFERENCE

370 N. MAIN ST., PO BOX 457, MARLBOROUGH, CT 06447  
 PH: (860) 295-6102, FAX: (860) 295-6107  
 Internet: www.imshome.com, E-Mail: info@imshome.com

### WARNINGS

- The rear mounting surface of the driver contains various voltages and must be kept isolated when attached to conductive materials.
- The heat sink mounting surface must be a smooth, flat surface with no burrs, protrusions, cuttings or foreign objects.
- Although stepping motors will run hot when configured correctly, damage may occur if a higher than specified current is applied. Most specified motor currents are maximum values. Care must be taken when exceeding these values.
- When using an unregulated power supply, the output voltage must not exceed the maximum driver input voltage due to variations in line voltage. It is recommended that an input line filter be used on the power supply to limit voltage spikes to the driver.
- When interfacing with the FAULT IN or RESET inputs, an open collector, tri-state output, or blocking diode is required or damage may occur to the internal circuits.
- Do not connect or disconnect the motor leads or the power supply with power applied! Disconnect the AC power side to power down the DC power supply.
- For battery operated systems, conditioning measures should be taken to prevent device damage caused by in-rush current draws, transient arcs and high voltage spikes.

## ELECTRICAL SPECIFICATIONS

Input Voltage ..... +12 to +48 Volts (Includes Back EMF)  
 Output Current\* ..... 0.14 to 1.5 Amps RMS, 2.1 Amps Peak  
 Step Frequency (Max) ..... 2.5MHz  
 Steps per Revolution

Available Microsteps Per Revolution						
400	800	1000	1600	2000	3200	5000
6400	10000	12800	20000	25000	25600	50000
51200	36000 <sup>1</sup>					

1=0.01 deg/μstep

Protection ..... Thermal, Phase to Phase, +V to Phase  
 Current Reduction\* ..... 0.5 Sec. After Last Step Input

\*Resistor Selectable

### Inputs

The inputs to the IM481H Plus are internally pulled-up to the +5VDC internal supply.

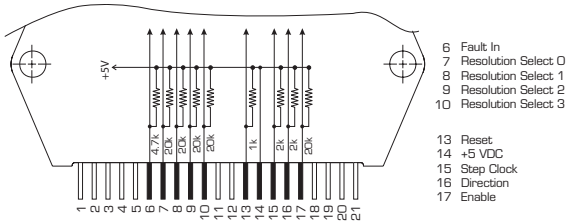

### +5VDC Input

The IM481H Plus requires an external regulated +5VDC power supply. The supply is connected between pin 11 (ground) and pin 14 (+5VDC.)

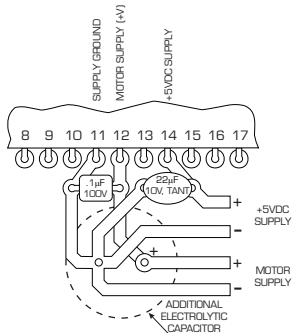

## Automatic Current Reduction

The IM481H Plus has the ability to automatically reduce the current in the motor windings after completion of a move. The reduction occurs 0.5 seconds after the last positive going edge of the Step Clock Input. The Driver will then revert to the original current setting upon the next positive going edge of the Step Clock Input. To utilize this feature, the current reference output must be used to adjust the reduced output current of the IM481H Plus and a resistor must be connected between pin 3 and pin 4.

Peak output current  
 (AMPS x 1000 = Resistor  
 Value Ohms)

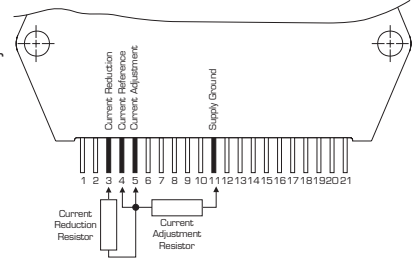

**$I_{Run}$  is the desired peak running current. Range 0.4A to 4A Peak**  
 **$I_{Hold}$  is the desired peak holding current. Range 0.2A to 4A Peak**

$$R_{Red} = 1000 \times \frac{I_{Run} \times I_{Hold}}{(I_{Run} - I_{Hold})}$$

## Test Values

TEST CONDITION	MIN	TYP	MAX	UNITS
Input Voltage	12	45	48*	V
Phase Output Current (RMS)	0.14		1.5	A
Phase Output Current (Peak)			2.1	A
Quiescent Current (+V, Pin 12)				
Inputs/Outputs/Floating	1			mA
Quiescent Current (+5V, Pin 14)				
Inputs/Outputs/Floating	100	150		mA
Active Power Dissipation ( $I_{OUT}$ =1A RMS)			2	W
Low Level Input Voltage (All Inputs)			1.2	V
High Level Input Voltage				
All Inputs Except Reset	2.0			V
Reset			2.3	V
Input Pull-Up Resistance				
Res Sel 0-3, Enable		20		kΩ
Step Clock Direction		2.0		kΩ
Reset		1.0		kΩ
Fault In		4.7		kΩ
Low Level Output Current				
Fault, Fullstep	2			mA
High Level Output Current				
Fault, Fullstep	-2			mA
Low Level Output Voltage ( $I_{OL}$ = 2mA)			0.5	V
High Level Output Voltage ( $I_{OH}$ = -1.7mA)	2.3			V
Step Clock				
Rate			2.5	MHz
Width	200			nS
Response		650		nS
Direction Setup/Hold		50/100		nS
MSEL Setup		4		mS
Full Step (zero cross) Response		650		nS
Reset Pulse Width		1		μS
Enable Response		4		mS
PWM Frequency (step rate dependent)	20		60	kHz

\* Includes back EMF of motor.

## Pin Assignment and Description

PIN#	PIN NAME	FUNCTION
1	Phase A	Phase A connection.
2	Phase A	Phase A connection.
3	Current Reduction Adjust	A resistor connected between Pin 3 and Pin 4 will proportionately reduce the current in both windings 0.5 seconds after the last positive edge of the step clock input.
4	Current Reference	A resistor is connected to Pin 4 (1mA current source output) and Pin 11 (ground) to generate voltage used to set the peak phase current in the motor.
5	Current Adjustment	A voltage applied to Pin 5 sets the peak phase current in the motor.
6	Fault Input	A low signal generates a latched fault.
7	Resolution Select 0	Microstep Resolution Select (See Microstep Sel. Chart)
8	Resolution Select 1	Microstep Resolution Select (See Microstep Sel. Chart)
9	Resolution Select 2	Microstep Resolution Select (See Microstep Sel. Chart)
10	Resolution Select 3	Microstep Resolution Select (See Microstep Sel. Chart)
11	Ground	Supply Ground
12	+V	+12 to +48VDC Supply
13	Reset Input	A low will reset the IM481H Plus. A high will allow the driver to return to its initial state. (Phase A off/Phase B on)
14	+5VDC	A +5VDC supply for the internal logic. It is referenced to Pin 11 (ground).
15	Step Clock Input	A positive going edge advances the motor one increment.
16	Direction Input	Changes direction of the motor.
17	Enable Input	Used to enable the input/output circuits of the driver. A high enables the driver.
18	On Full Step Output	A totem-pole output used to indicate when the driver has positioned at a full step. Can be used as a counter for full steps.
19	Fault Output	A totem-pole output used to indicate a short circuit has occurred or the Fault Input is low.
20	Phase B	Phase B connection.
21	Phase B	Phase B connection.

**WARNING!** When interfacing the FAULT IN/RESET input, an open collector, tri-state output or blocking diode is REQUIRED or damage may occur. Please see the IM481H Plus Product Manual at www.imshome.com for more details and for controlling multiple Drives with One Reset.

**For More Information:**  
 See the complete IM481H Plus Product Manual on the IMS Product CD or at [www.imshome.com](http://www.imshome.com)

## Thermal Specifications

Storage ..... -40° to +125° C  
 Rear Mounting Surface\* ..... -40 to +85° C

\*External heat sink may be required to maintain mounting surface below 85° C. Isolating thermal pad is required when using additional heat sink.

## Microstep Selection

Microstep Resolution (MSEL) Settings					
RESOLUTION (Microsteps/Step)	STEPS/REV (1.8° Step Motors)	MSEL 0 (P1:5)	MSEL 1 (P1:6)	MSEL 2 (P1:7)	MSEL 3 (P1:8)
BINARY					
2	400	LOW	LOW	LOW	LOW
4	800	HIGH	LOW	LOW	LOW
8	1,600	LOW	HIGH	LOW	LOW
16	3,200	HIGH	HIGH	LOW	LOW
32	6,400	LOW	LOW	HIGH	LOW
64	12,800	HIGH	LOW	HIGH	LOW
128	25,600	LOW	HIGH	HIGH	LOW
256	51,200	HIGH	HIGH	HIGH	LOW
DECIMAL					
5	1,000	LOW	LOW	LOW	HIGH
10	2,000	HIGH	LOW	LOW	HIGH
25	5,000	LOW	HIGH	LOW	HIGH
50	10,000	HIGH	HIGH	LOW	HIGH
125	25,000	LOW	LOW	HIGH	HIGH
250	50,000	HIGH	LOW	HIGH	HIGH
FULL STEP					
1	200	LOW	HIGH	HIGH	HIGH
DEGREES					
180	36,000	HIGH	HIGH	HIGH	HIGH

## Connecting the Motor

### 4 Lead Motors

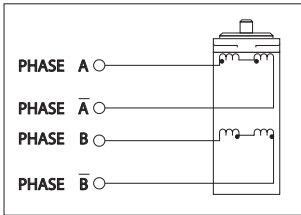

Motor Peak Current =  
 Rated Amps/Phase x 1.4

### 8 Lead Motors

#### Series Connection

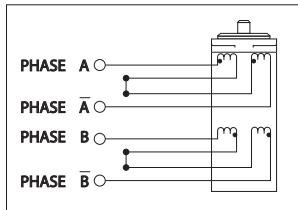

Motor Peak Current =  
 Rated Amps/Phase x 1  
 or  
 Motor Peak Current =  
 Bipolar Current Rating x 1.4

### 6 Lead Motors

#### Full Coil Configuration

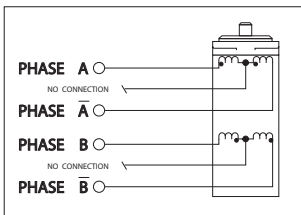

Motor Peak Current =  
 Rated Amps/Phase

#### Parallel Connection

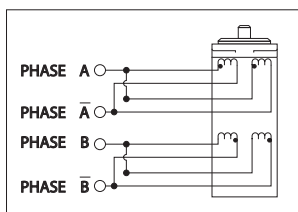

Motor Peak Current =  
 Rated Amps/Phase x 2  
 or  
 Motor Peak Current =  
 Bipolar Current Rating x 1.4

### Half Coil Configuration

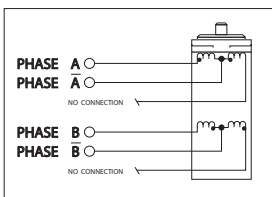

Motor Peak Current =  
 Rated Amps/Phase x 1.4

**MAXIMUM**  
 Motor Inductance (mH/Phase) =  
 0.2 x Minimum Supply Voltage

## Timing

A positive going edge at the Step Clock Input will advance the motor one step. The pulse must be a minimum 200nS wide. The IM481H Plus will present new phase data to the internal D/A converters 650nS after the Step Clock edge.

The Direction input must be stable on the positive going edge of Step Clock, and must be held for a minimum of 50nS after the step clock that advances a phase to zero cross.

The On Full Step output will assert 650nS after the Step Clock that advances a phase to zero cross.

The Reset and Enable inputs are asynchronous and may be asserted at any time.

The Reset requires a minimum pulse width of 1µS.

## Options and Accessories

Isolating Thermal Pad .....TI-481  
 Interface Board.....INT-481  
 Heat Sink (includes hardware) .....H-481  
 21 Pin Right Angle Connector .....HY481-CN021  
 Small End Screwdriver .....SD1

## IM481H Plus Mechanical Dimensions and Mounting

Dimensions in Inches (mm)

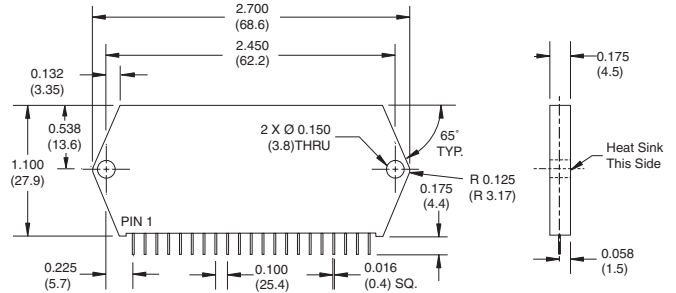

### IM481H Plus with H-481 Heat Sink Direct PCB Mounted

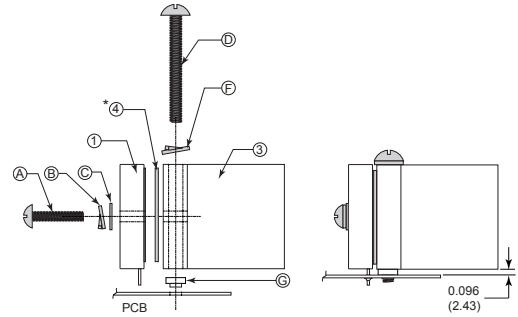

### Hole Pattern for PCB Mount

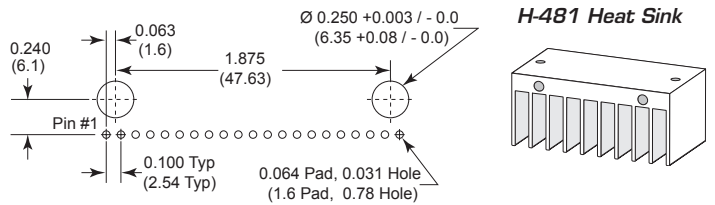

### H-481 Heat Sink

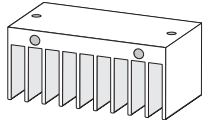

### IM481H Plus with INT-481 and H-481 Panel Mounted

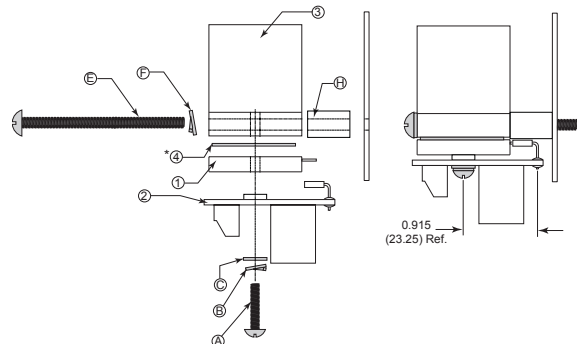

### IM481H Plus with INT-481 Panel Mounted

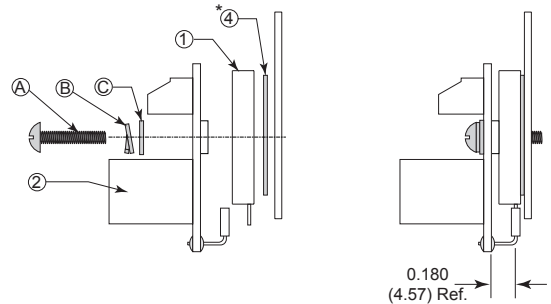

NOTE: The hardware items "A" through "H" are supplied with the H-481 Heat Sink Kit. If the H-481 is not used, the mounting hardware is not supplied.

NOTE: The torque specification for the #6-32 INT-481 and IM481H Plus mounting screw is 5.0 - 7.0 in-lbs.

Item #	Description	Qty.
1	IM481H Plus Microstepping Driver	1
2	INT-481 Interface Board	1
3	H-481 Heat Sink	1
4	TI-481 Isolating Thermal Pad	1
A	#6-32x5/8" Pan Head Screw	2
B	#6 Split Lock Washer	2
C	#6 Flat Washer, 0.250" OD, 0.145" ID, 0.030" Thick	2
D	#8-32x13/8" Pan Head Screw	2
E	#8-32x2 Pan Head Screw	2
F	#8 Split Lock Washer	2
G	#8-32 Internally Threaded Broaching Nut	2
H	Spacer, 0.312" OD, 0.171" ID, 0.500" Long	2



WARNING! The Heat Sink mounting surface must be a smooth, flat surface with no burrs, protrusions, cuttings or other foreign objects.

WARNING! If you are planning to wash your PCB it must be done prior to adding the IM481H Plus Driver or damage will occur.